

BSP-15

BSP15 Performance

Discharge Head	0ft.	2ft.	4ft.	6ft.	8ft.	10ft.
Gallons/Hour	1750	1668	1512	1302	948	720

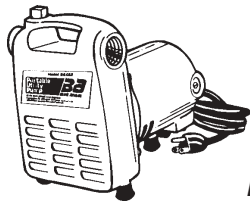

EC50

Capacity Chart in Gallons per Hour

Suction Lift in Feet	Discharge Pressure Lbs. Per Square Inch							
	5	10	15	20	25	30	35	40
0	1450	1370	1250	1140	1020	890	750	610
5	1420	1300	1190	1070	950	820	680	540
10	1350	1230	1120	1000	880	750	620	480
15	1270	1160	1040	830	810	570	550	410

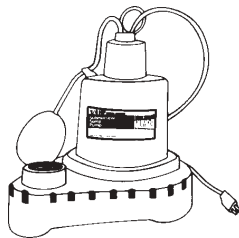

BWST30

Capacities

Discharge Head	5ft.	10ft.	15ft.	20ft.
Gallons/Hour	2880	2220	1620	740

## Sump and Sewage Pumps and Accessories

Model#      Description      Code #

### Utility and Sump Pumps

**BSP-15**      12V Standby Sump Pump System. This stand-by system works off standard or marine battery. Includes mercury switch for automatic operation, battery charger to keep battery properly charged, alarm system to let homeowner know when activated, battery case, battery reverse signal, built-in check valve. (Does not include pump)

Emergency Pump      381-0115

**EC-50**      Electric Portable Utility Pump, high capacity, self-priming. Pump from any source or boost line pressure 40 pounds. Pump housing - solid, one piece aluminum casting, corrosion resistant. Impeller - glass reinforced thermoplastic. Ball bearings - permanently lubricated. Shaft seal - ceramic and brass construction, liquid lubricated. 1/2 HP Motor - 7500 RPM motor operates with either 115V AC or DC power. Power cord with ground wire connection and 3/4" garden hose adapters.

Porta Pump 115V      381-0120

**BWST30**      Thermoplastic submersible sump pump with mercury switch. 3/10 HP motor automatically turns on when the water level reaches 10" and turns off at 4". Compact design allows installation in a 14" or wider sump basin. 1-1/2 NPT standard discharge. 3-prong foot, UL Listed cord. Intake screen allows for top suction. 3/10 HP, 115V, SP, 60HZ.

Sump Pump 3/10 HP      381-0130



**blue angel  
PUMPS™**



BCS33

Capacities

Discharge Head	5ft.	10ft.	15ft.	20ft.	25ft.
Gallons/Hour	3600	2820	1800	480	--



BTU33

Capacities

Discharge Head	5ft.	10ft.	15ft.	20ft.
Gallons/Hour	2820	2280	1620	540



BSPF-33

Capacities

Discharge Head	5ft.	10ft.	15ft.	20ft.	25ft.
Gallons/Hour	3300	2520	1380	120	—



BSPT-33

Capacities

Discharge Head	5ft.	10ft.	15ft.	20ft.	25ft.
Gallons/Hour	3300	2520	1380	120	—

Model#	Description	Code #
--------	-------------	--------

**BCS-33** Cast iron submersible Sump Pump with mechanical float switch. 1/3 HP motor automatically turns on when the water level reaches 9" and turns off at 3-1/2". Compact design allows installation in a 10" or wider sump basin. Cast iron volute resists corrosion, 1-1/2" discharge. Two pole mechanical float switch, automatic overload protection. 3-prong 8 foot grounding type cord. Permanently lubricated ball bearing. Carbon ceramic-seal protects electric motor. Top suction strainer and thermoplastic top assembly.

Sump Pump 1/3HP 381-0140

**BTU-33** Thermoplastic pedestal sump pump with 1/3 HP motor, 1-1/2" Discharge Pedestal pump 1/3HP 381-0160

**BSPF-33** Submersible sump thermoplastic pump with 1/3 HP motor and mechanical float switch. Compact design allows installation in an 11" or wider sump basin. Two pole mechanical float switch. Automatic overload protection. Thermoplastic volute and top assembly, 1-1/2" discharge. 3-prong 8 foot grounding type cord. Permanently lubricated ball bearing. Carbon-ceramic seal protects electric motor. Top suction and removable screen.

Sump pump 1/3HP 381-0215

**BSPT-33** Submersible sump thermoplastic pump with 1/3 HP motor and tethered mechanical float switch. Designed to operate in a 14" or wider sump basin. Thermoplastic volute and top assembly, 1-1/2" discharge. Automatic overload protection. 3-prong 8 foot grounding type cord. Permanently lubricated ball bearing. Carbon-ceramic seal protects electric motor. Top suction and removable screen.

Sump pump 1/3HP 381-0255



June 1, 2006



SEWAGE EJECTORS

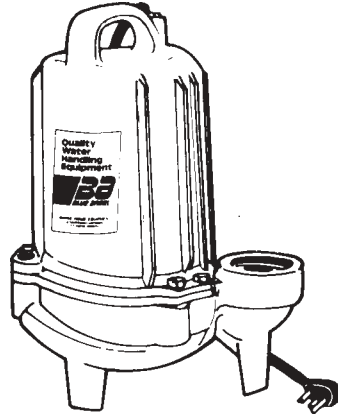

BEF50T, BEF75T

PERFORMANCE

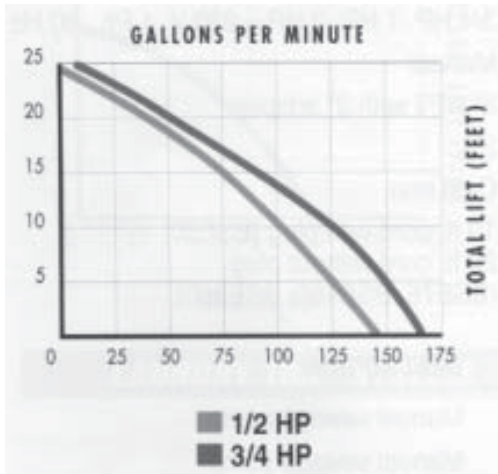

BSEL SERIES CAPACITY (GALLONS/MINUTE)		
Total Head (Feet)	PUMP BSEL 40	BSEL 50
10	78	107
15	45	70
20	-	25

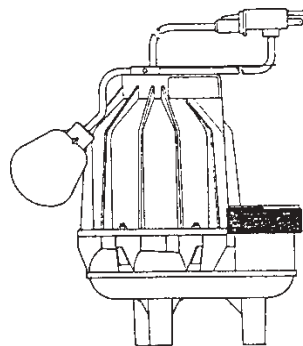

BSEL40, BSEL50

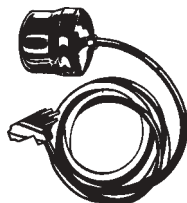

Mercury Switch Kit  
56836-1

Model#            Description            Code #

**Fully Submersible Sewage Ejector Pumps -**

BEF50T    Cast iron 1/2HP pump with 2-vane impeller. Split phase 1725 rpm motor, 120V. Cast iron motor housing, seal plate and volute for reliability. Ball bearings for quiet operation and long life. Easy impeller cleanout/service. Oil filled motor is thermally protected to prevent overheating. Stainless steel fasteners for superior corrosion-resistance, with tethered float switch, 2" NPT Discharge, 2" Solids Sewage Pump            381-0420

BEF75T    Same as above but with 3/4HP 120V motor. Sewage Pump            381-0425

**Economy Fully Submersible Sewage Ejector Pumps With Switch**

BSEL 40    4/10 HP heavy duty oil-filled motor with 120V single phase and overload protector. Rugged polymer construction, one piece cast iron bracket with journal bearing. Pumps 2" solids. Combination 2"-3" NPT discharge. Unitized shaft seal. Vortex impeller, stainless steel fasteners. 8' cord.

Sewage Ejector            381-0430

BSEL50    Same as above but with 1/2 HP split phase motor with solid state start switch. Sewage Ejector            381-0435

56836-1    Mercury switch kit with 9 foot cord            381-0480



1/3 HP  
3/8" Solids  
1-1/4" Discharge

TURN ON LEVEL 7.5"  
TURN OFF LEVEL 3.5"

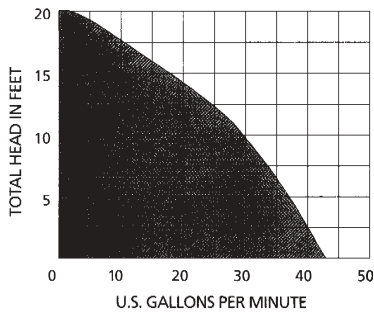

1/4 HP  
1/4" Solids  
1-1/2" Discharge

TURN ON LEVEL 6.5"  
TURN OFF LEVEL 3.5"

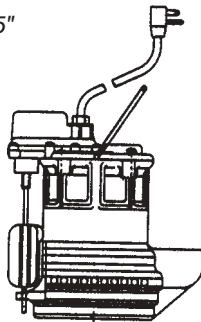
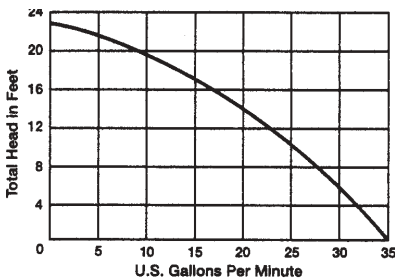

1/3 HP  
1/2" Solids  
1-1/2" Discharge

TURN ON LEVEL 6.5"  
TURN OFF LEVEL 3.5"

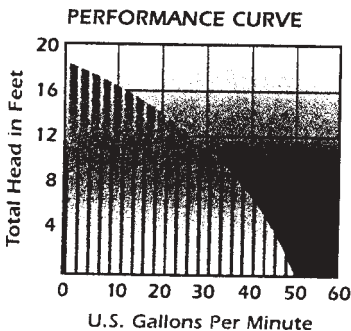

Model#	Description	Code #
--------	-------------	--------

**Submersible Sump Pump**

**Model 237**

Polypropylene/anodized aluminum pump for small pit applications; 9.75" diameter or larger . Trouble-free switch in a vertically-operated control. Float shape is engineered to give optimum buoyancy while providing close proximity to the side of the pump. Heavy-duty, 115V, oil filled motor with thermal overload protection, vortex style impeller, permanently sealed and lubricated bearings. 10' UL approved power cord, stainless steel rotor shaft, unitized shaft seal. Maximum fluid temperature: 140 degrees F.

237	Sump Pump 1/3 HP Submersible	381-1010
-----	------------------------------	----------

**Model 247**

Unique One-Piece Cast Iron housing, rugged 1/4 HP Motor, 115V, oil filled with thermal overload protection. UL Approved 10' quick-disconnect power cord. Magnetically operated vertical float switch, 1/4" solids handling 1-1/2" discharge.

247	Sump Pump Submersible	381-1015
-----	-----------------------	----------

**Model 257**

Unique One-Piece cast iron housing. Features 1/3 HP, 115V, oil filled motor, thermally protected. Vortex style impellar prevents clogging by foreign materials, 1/2" solids-handling suitable for effluent pump applications 10' UL approved power cord. Vertical magnetic float for smaller pits down to 10" diameter. 1-1/2" discharge.

257	Sump Pump 1/3 HP Submersible	381-1020
-----	------------------------------	----------

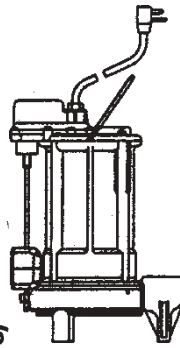

Model#	Description	Code #
--------	-------------	--------

**Sump Pump**

Model 287

Unique one-piece cast iron housing. Features 1/2 HP, 115V Oil filled motor. Vortex style impeller, permitting passage of solids up to 3/4". 10' UL power cord. Vertical magnetic float for smaller pits down to 10" diameter. 1-1/2" discharge.

287 Sump Pump 1/2hp  
Submersible 381-1025

**Performance Curve: 280-Series**

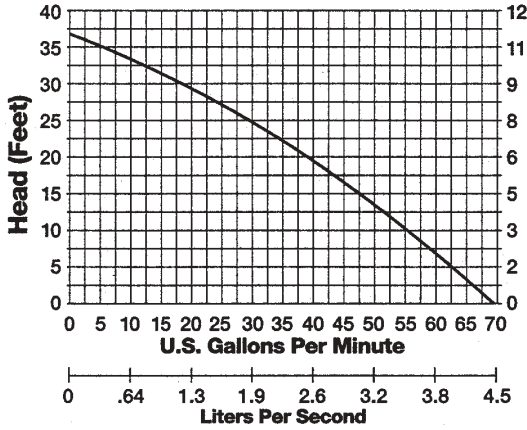

**Sewage Pump**

Model LE41A

4/10 HP, 2" solids handling, 2" discharge, 1550 rpm cast iron construction, 10' UL power cord, mercury free float switch with series plug.

LE41A w/10' power cord 381-1045



Model LE51A

1/2 HP, 2" solids handling, 2" discharge, 1725 rpm, cast iron construction, 20' UL power cord, mercury free float switch with series plug.

LE51A w/10' power cord 381-1050

**PERFORMANCE CURVE**

115V and 230V

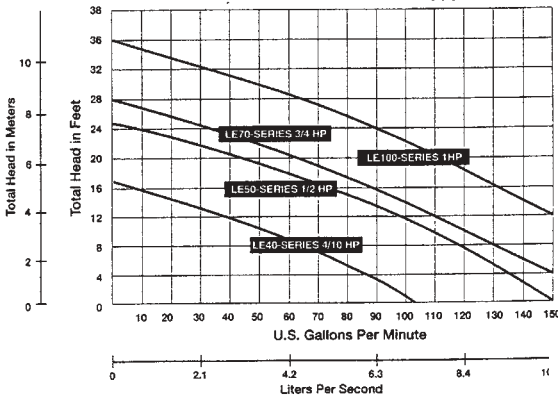

**SIMPLEX Pro370-Series**

Integrally molded anti-flotation collar  
Integrally molded inlet sized to accept a 4" flexible coupling, polyethylene construction with radial ribs for added strength. Completely assembled at the factory with a schedule 80 PVC discharge pipe.

Available with any of Liberty's 2" solids handling sewage pumps

Available with pre-mounted alarm floats

Model P372-LE41 4/10 HP 381-1098

Model P372-LE51 1/2 HP 381-1102



**Specifications: 2" Discharge Systems**

MODEL	HP	VOLTS	PHASE	DISCHARGE	WGT. LBS.
P372LE41	4/10	115	1	2"	60
P372LE51	1/2	115	1	2"	64
P372LE52	1/2	208-230	1	2"	63
P372LE71	3/4	115	1	2"	63
P372LE72	3/4	208-230	1	2"	63
P372LE102*	1	208-230	1	2"	66
P372LEH102*	1	208-230	1	2"	66

For 3" discharge systems change model number from "372" to "373."  
EXAMPLE: P373LE41

See specific LE-Series literature for complete pump performance and specifications.  
\*High head applications only. Consult factory for proper pump sizing.

**Specifications: 2" Discharge Systems**

MODEL	HP	VOLTS	PHASE	DISCHARGE	WGT. LBS.
P382LE41	4/10	115	1	2"	60
P382LE51	1/2	115	1	2"	64
P382LE52	1/2	208-230	1	2"	63
P382LE71	3/4	115	1	2"	63
P382LE72	3/4	208-230	1	2"	63
P382LE102*	1	208-230	1	2"	66
P382LEH102*	1	208-230	1	2"	66

For 3" discharge systems change model number from "382" to "383."  
EXAMPLE: P383LE41

See specific LE-Series literature for complete pump performance and specifications.  
\*High head applications only. Consult factory for proper pump sizing.



**SIMPLEX Pro380-Series**

Fully Assembled and shipped with a clear disposable construction cover. Available with any of Liberty's 2" solids-handling sewage pumps. Inspection/Access Cover. Integral rubber seals. Larger capacity basin results in decreasing switch cycles and improving pump life. Integrally molded torque stops secure the pump in its proper position. Integrally molded anti-flotation collar.

Model P382-LE41 4/10 HP 381-1150

Model P382-LE51 1/2 HP 381-1160



Model#	Description	Code #
--------	-------------	--------

**SBX-Series SumpBox®**

- Fully Assembled and shipped with a clear disposable construction cover that will protect the system during rough-in and masonry work
- Unique debris filter tray
- Large 41 gallon capacity
- Easy access cover requires no tools to open
- Easy to service float switches located in holders under access cover
- Sealed covers radon-ready

SBX35	1/3 HP Pump, 115V	381-1180
-------	-------------------	----------

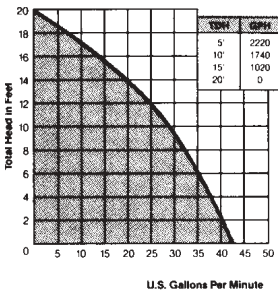

Dimensions:  
14-3/4"W x 14-1/2" H

**Pre-Assembled Automatic Drain Pump**

Model 403

Fully automatic operation, oil-filled hermetically sealed motor with thermal-overload protection; 10 ft., 3 wire power cord with grounded plug. Integral corrosion-resistant poly-olefin receiver with all molded-in connections, over 5 gallon capacity. Permanently lubricated sealed bearings. 1-1/2 FPT Inlet, 1-1/2" FPT discharge, 1-1/2" FPT vent.  
Applications: Laundry tray, mop sink, bar sink, or wherever drainage is needed below gravity lines.

403	Automatic Drain Pump Pkg	381-1200
-----	--------------------------	----------

Liberty "Brick" Pump Platform	381-1300
Raises the sump pump 2.5" off the bottom of your pit. Fits Liberty submersible sump pump.	



## Jackel Tanks

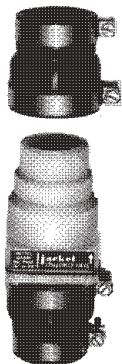
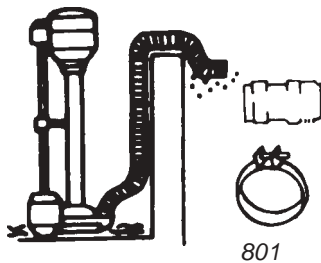
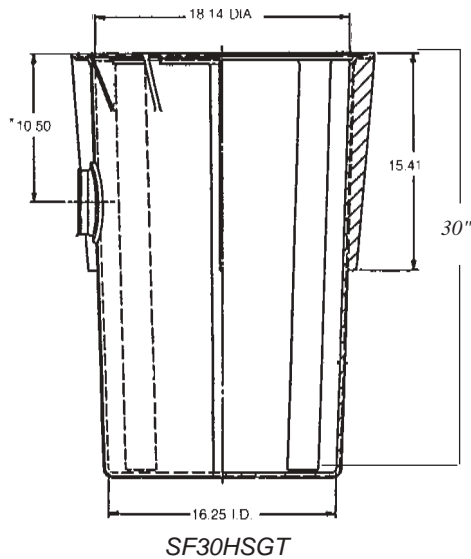
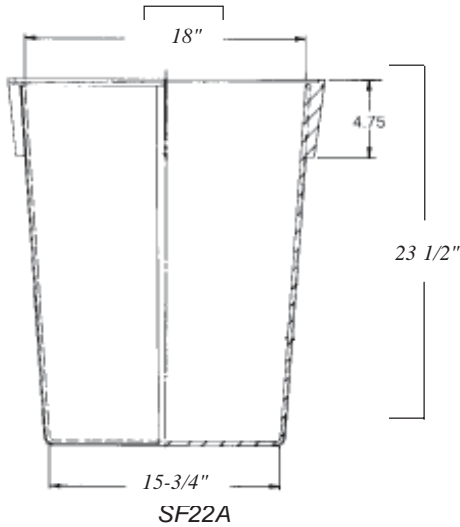

Model#	Description	Code #
--------	-------------	--------

Structural foam sump tank is a 22.5 gallon basin that collects water. Cover included is made of polyglas with threaded inserts in tank, one hole foam cover and bolts. Has bolts and connections.

SF22A	Sump Pump Complete	381-4400
	Replacement cover for SF22A	381-4401
	Anchor Thrd Sump Tank	381-4402
	Replacement bolt package (4 bolts)	384-4403

Structural foam sewage ejector pit is a 18 x 30" - 30 gallon capacity basin that collects sewage and waste water for pump discharge to a septic tank or city sewer lines. 4 inch hub with gasket.

SF30HSGT	2 inch discharge	381-4430
	Anchor Thrd Sewage Pit	381-4444
	Replacement cover for 2" SF30HSFT	381-4445
	Hub Gsk with SS Clamp	381-4447

Sump pump drain kit with 24 feet flex poly drain hose, one 1-1/4" male plastic insert adapter and one stainless steel clamp

801	381-4450
-----	----------

Check Valve - checks back flow of water and sewer gas, cushioned to eliminate clatter, stops electrolysis. Reduces vibration and pump cycling. Plastic body complete with two rubber adapters and connecting hose clamps. Valve will accept both 1-1/4" and 1-1/2" black, galvanized or DWV plastic pipe - also 1-1/2" or 2" copper DWV by use of the two reversible rubber adapters.

DJ-545	381-4460
--------	----------

Check Valve - checks back flow of water and sewer gas, cushioned to eliminate clatter, stops electrolysis. Full flow swinging flapper with stainless steel backup plate. Body of polycarbonate, complete with connecting hose clamps. Designed to fit 2" black, galvanized or DWV plastic pipe.

2-GP	Check Valve - 2 inch	381-4470
CH150S	Check Valve - 1-1/2 inch	381-4480



15JSD

S.J. Electro

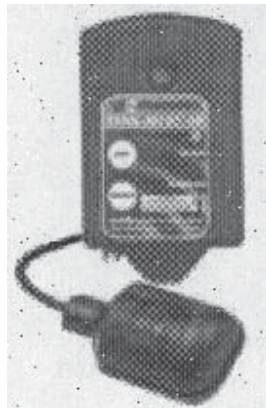

AB

Model#	Description	Code #
--------	-------------	--------

The Junior Super Single Pump Down (Emptying) Switch consists of one float, 15 foot cord with a piggy-back plug, one large mounting strap, and two small adjustable mounting clamps. Controls pumps of up to 1/2HP (120V). Float houses the mercury tilt switch with the mercury-to-mercury contact. Adjustable pumping range. 120V, 60HZ, Single phase, Max 13 amp run, 40 amp start.

15JSD	Pump Switch	381-4500
-------	-------------	----------

The Tank Alert AB alarm system with auto-reset & battery backup for indoor use includes alarm panel, sensor float, 12 foot cord and splice kit. The sensor float is lowered into the tank and secured at desired level. When the liquid level rises the internally weighted sensor float tips and activates a loud horn in the alarm panel, and a warning light. 120V, 60HZ, 15 amp. Battery 9V DC

AB	Tank Alarm	381-4550
----	------------	----------

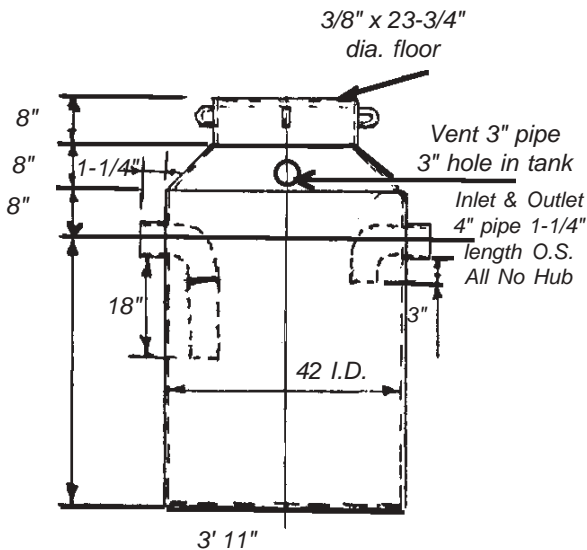

WASTE TRAP

	Standard Inflammable Waste Trap	381-5000
--	---------------------------------	----------

with 2 elbows and extension piece, 1/4" cone & neck, 3/16" shell and bottom with protective coating, 35 cubic ft. capacity.